

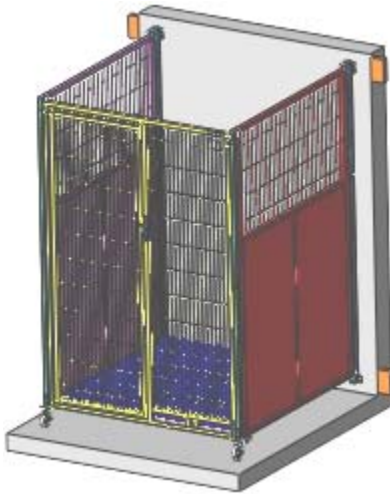

415 Osage Avenue, Kansas City, KS 66105
Phone: 913-281-0722
Fax: 913-281-3315
www.t-kennel.com



Folding Wall Mount Kennel Installation

TABLE OF CONTENTS

SECTION	PAGE
INTRODUCTION	3
A. Tools Required	4
B. Kennel Assembly Hardware	5
C. Hinge, Side Panel Pivot Installation	6
D. Installing Pin, Quick Release	7
E. Installing Floor and next Hinge, Side Panel Pivot	7-8
F. Assembling Side Panel Assembly	8-9
G. Place Side Panel Assembly on Hinge, Side Panel Pivot	10
H. Installing Gate Panel	11-13
I. Install Striker Bar and Latch Assembly	14
J. Folding up Kennel	14

INTRODUCTION

Thank you for placing your trust in T-Kennel Systems. T-Kennel values you as a customer and will do everything we can to provide quality products and service, to assure your experience with T-Kennel is a pleasant one.

The animal kennel system you have purchased has been precision made and shipped according to your instructions. Once assembled, your system will look custom built and especially made for your animal holding area.

For your personal safety, the safety of your workers, the public safety, and to maintain your kennel system it is very important to read and follow all instructions.

KENNEL INSTALLATION MANUALS ARE AVAILABLE FOR:

Single Kennel Installation on Raised Floor

Double Kennel Installation on Raised Floor

Single Kennel Installation on Concrete Floor

Double Kennel Installation on Concrete Floor

Space Saver Single Kennel Installation on Raised Floor

Double Decker Installation on Concrete Floor

Double Decker Installation on Raised Floor

Quad Installation on Concrete Floor

Quad Installation on Raised Floor

Space Saver 2.0 Single Kennel Installation on Raised Floor

Space Saver 2.0 Single Kennel Installation on Concrete Floor

Folding Wall Mount Kennel Installation

SAFETY FIRST:

▲ | CAUTION Kennels are heavy and precautions must be taken to protect from personal injury. Get help when lifting heavy parts.

▲ | CAUTION Edges of steel and stainless steel kennels and parts may be sharp. We recommend that you always wear protective gloves during unloading, inspection and assembly.

▲ | WARNING T Kennel products are designed for animal use only. Never allow a person in or on your Kennel Assembly.



A. Tools Required (Not Included)

This list of tools is the minimum required to install/assemble your Kennels. Depending on your facility and kennel configuration, you may need additional tools and/or specialty tools.

 <p>RATCHET/SOCKET WRENCH WRENCH 5/16" AND 7/16"</p>	 <p>SCREW GUN</p>
 <p>7/16" COMBINATION WRENCH</p>	 <p>4 FT. LONG LEVEL</p>
 <p>5/16" HEX HEAD DRIVER</p>	

Other Tools: Tape Measure, Straight-Line (Laser or String), Pry-Bar, Screw Driver, Hammer, Chalk Line, Saw Zall with Bi-Metal Blade, Hammer Drill with concrete Bit, Tin Snip and Hacksaw.

B. Kennel Assembly Hardware

Hardware pictured below is for the assembly of T Kennel's standard Kennel System. Your hardware may vary depending upon your kennel configuration, building design, etc. Please feel free to call our Sales Department or Tech Services Department if you have any questions.



041.0069.02
STRIKER BAR



731.0000.00
LATCH ASSEMBLY-LH

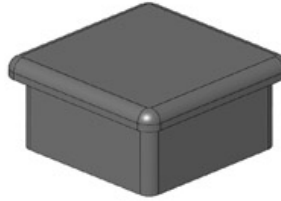

051.0000.19
CAP, PLASTIC 1X1

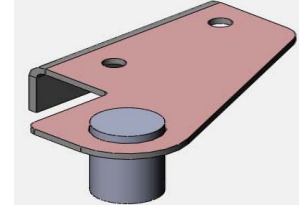

825.00065
HINGE, UPPER GATE PIVOT



061.1010.00
#12X1 TEK SCREW



061.1020.01
#12X2 TEK SCREW



062.2515.00
1/4-20X1.5 CAP SCREW



064.2500.22
1/4-20 NYLOCK NUT

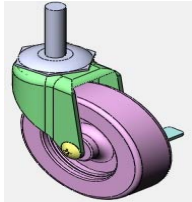

041.0149.01
CASTER, SWIVEL
w/ BRAKE



041.0175.00
LATCH, SLIDING BOLT



041.0176.00
PIN, QUICK RELEASE



825.00064
HINGE, LOWER GATE PIVOT



825.00069
HINGE, SIDE PANEL PIVOT

C. Hinge, Side Panel Pivot Installation

<p style="text-align: center;">FIGURE 1</p>	<p>Notes:</p> <ol style="list-style-type: none"> 1. First, measure 2 1/8" from high point in floor (Figure 1) and strike a chalk mark along wall where Folding Wall Mount Kennels are to be installed. High point can be up to 48" out from wall where Caster w/ Brake will be traveling in an arc. 2. Hinge, Side Panel Pivot must be vertical in both directions (<i>front to back</i> and <i>side to side</i>) in order to operate properly. Care must be taken in order to insure this. 3. <i>Suggested floor slope is flat.</i> 4. Installation will always start on the left hand side and build to the right.
<p>(4) installer supplied 1/4" dia. wall screws</p> <p>Hinge, Side Panel Pivot</p>	<p style="text-align: center;">AT TOP Figure 1A</p>
<p style="text-align: center;">AT BOTTOM Figure 1B</p>	<p>Pivot Tube, Floor (ref)</p> <p>Hinge, Side Panel Pivot</p> <p>(2) installer supplied 1/4" wall screws</p>

D. Installing Pin, Quick Release on Floor

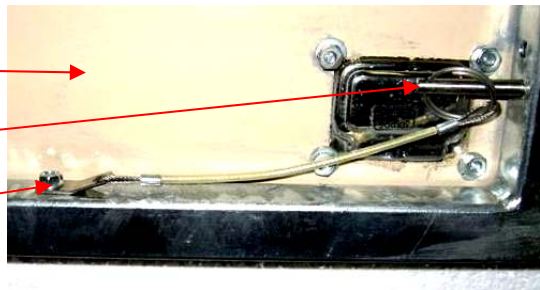
<p style="text-align: center;">Floor →</p> <p style="text-align: center;">Pin, Quick Release →</p> <p style="text-align: center;">#12x1 Tek Screw →</p> <p>Make sure that Pin has enough lead that it can travel thru past Floor tube frame before securing in place with Tek Screw.</p> <p style="text-align: center;">Assemble all Floors at this time.</p>	 <p style="text-align: center;">Bottom side of Floor Figure 2</p>
--	---

E. Installing Floor and next Hinge, Side Panel Pivot

- Two people will be required to install **Floor**. The first person will insert the pin on left outside of **Floor** (shown in **Figure 3**) into **Tube, Pivot, Floor, Hinge**. Raise **Floor** to vertical position and place **Pin, Quick Release** thru hole and into slot in side of **Hinge, Side Panel Pivot** as shown in **Figure 3A**. Use a **Clamp** to hold **Floor** in place while the next **Hinge, Side Panel Pivot** is slipped over the pin on the right side of outside of **Floor** (**Figure 3B**).

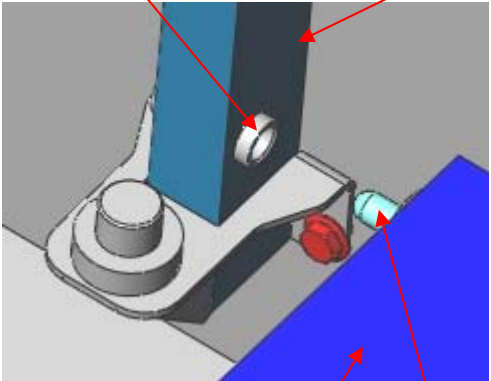
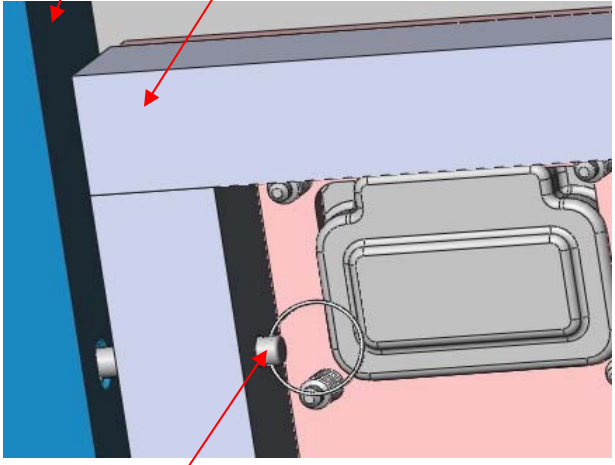
<p style="text-align: center;">← Tube, Pivot, Floor, Hinge</p> <p style="text-align: center;">Hinge, Side Panel Pivot →</p>  <p style="text-align: center;">Floor →</p> <p style="text-align: center;">← Left side Pin, Pivot. Floor</p> <p style="text-align: center;">Figure 3</p>	<p style="text-align: center;">← Hinge, Side Panel Pivot</p> <p style="text-align: center;">← Floor</p>  <p style="text-align: center;">← Pin, Quick Release</p> <p style="text-align: center;">Figure 3A</p>
--	---

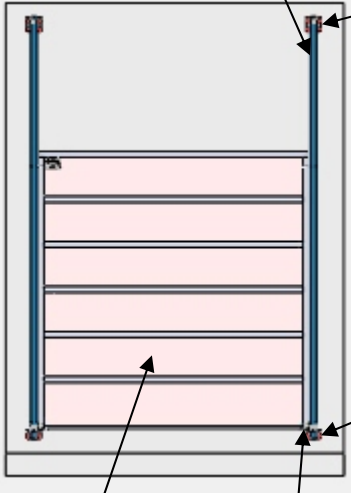
<p>2nd Hinge, Side Panel Pivot</p>  <p>Floor</p> <p>Figure 3 (similar)</p> <p>Figure 3B</p>	<p>See Figure 1A</p> <p>See Figure 1B</p> <ol style="list-style-type: none"> 2. While first person holds Hinge, Side Panel Pivot in place the second person levels Hinge, Side Panel Pivot in both vertical directions and attaches to wall. (Figure 1, 1A, 1B) Repeat as needed per your signed off drawings.
---	--

F. Assembling Side Panel Assembly



825.00064

HINGE, LOWER GATE PIVOT

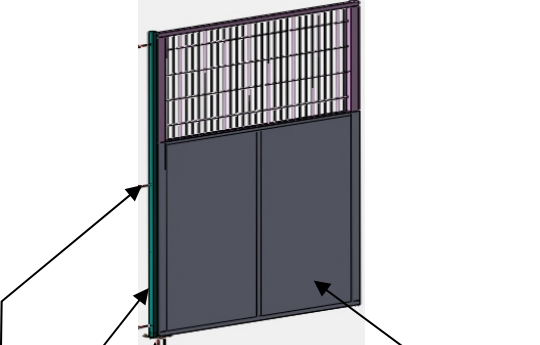
 <p>See Figure 4A</p> <p>Hinge, Lower Gate Pivot</p> <p>Side Panel</p> <p>(3) #12x2 Mounting Tek Screw</p> <p>Figure 4</p>	<ol style="list-style-type: none"> 1. Attach Hinge, Lower Gate Pivot to the Side Panel using (3) 2" Self-Drilling Tek Screws in front through pre-drilled holes and (2) #12x1 Self-drilling Screws on bottom (Figure 4 and 4A). See Figure 4A to see orientation of Hinge, Lower Gate Panel correctly on Side Panel. 2. Top of Plate, Base Front Hinge on Hinge, Lower Gate Pivot should butt against bottom of Side Panel. (Figure 4A) 3. Side of Hinge, Lower Gate Pivot should line up with side of frame of Side Panel. (Figure 4B)
---	---

Hinge, Lower Gate Pivot

Plate, Base Front Hinge (ref)

Side Panel

(2) #12x1 Mounting Tek Screw

4. Plate, Base Front Hinge of Hinge, Lower Gate Pivot must be on Side Panel *side* as shown in Figure 4A

Figure 4A

Hinge, Lower Gate Pivot

Side Panel

#12x2 Mounting Tek Screw

5. Side of Hinge, Lower Gate Pivot and Side Panel to line up as shown in Figure 4B

Figure 4B

Hinge, Lower Gate Pivot

Caster Swivel w/ Brake

6. Next, screw Caster Swivel w/Brake into bottom of Hinge, Lower Gate Pivot where shown in Figure 4C

7. Assemble all Side Panels, Hinge, Lower Gate Pivots and Caster w/Brakes at this time.

Figure 4C

6. Next, screw Caster Swivel w/Brake into bottom of Hinge, Lower Gate Pivot where shown in Figure 4C

7. Assemble all Side Panels, Hinge, Lower Gate Pivots and Caster w/Brakes at this time.

G. Place Side Panel Assembly on Hinge, Side Panel Pivot

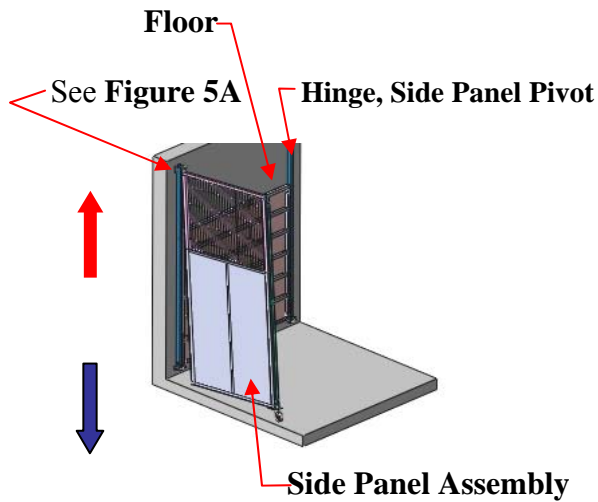
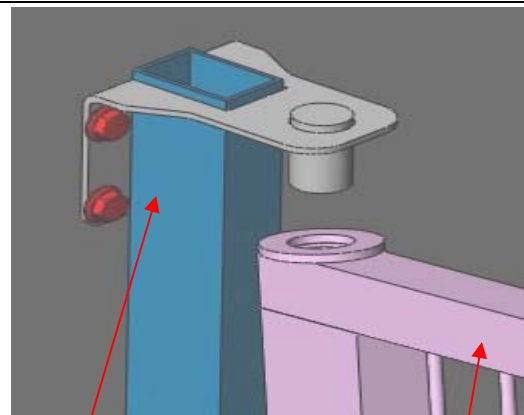

Figure 5

1. Take **Side Panel Assembly** and tip it as shown in **Figure 5**. Slide upper part of **Side Panel Assembly** under **Hinge Pin, Upper** on **Hinge, Side Panel Pivot** (**Figure 5A**). Then rotate bottom of **Side Panel Assembly** so that it fits on **Pivot, Hinge-Side Panel, Lower** on **Hinge, Side Panel Pivot**. Let **Side Panel Assembly** rest on **Pivot, Hinge-Side Panel, Lower** of **Hinge, Side Panel Pivot**.



Hinge, Side Panel Pivot

Side Panel Assembly

Figure 5A

2. Continue to place assemblies across wall. If assembly starts to roll, lock **Caster w/ Brake** to hold in place.

3. At this time, if jam nut exists on **Caster w/ Brake**, adjust **Caster** at this time with adjusting nut.

H. Installing Gate Panel

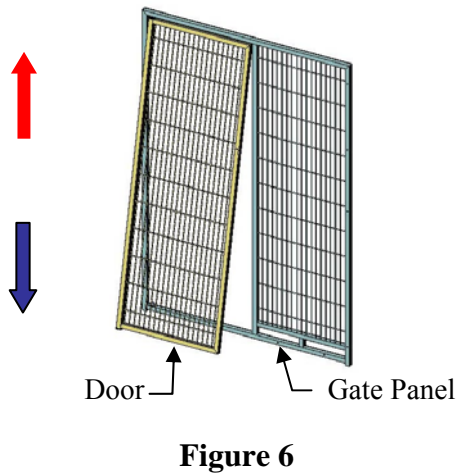

1. Locate the **Gate Panels** and remove the **Door** from each **Gate Panel** by slightly opening and lifting up on the **Door**. Once the **Door** clears the hinge pin at the bottom, pull the bottom of **Door** toward you (**Figure 6**). Pull the top of the **Door** down until the top of the **Door** clears the top hinge pin.

Mark all of the **Doors** so that they match with the original **Gate Panels**. Put the **Doors** aside until all the **Gate Panels** are ready to attach.

2. Release brake on Caster for Side Panel Assembly

3. Pull **Pin, Quick Release** out of hole it is in **Floor** (shown in **Figure 3A**) and put **Floor** in lower position with front of **Floor** resting on **Plate, Base-Front Hinge** located on front of **Side Panel Assembly**. (**Figure 7**)

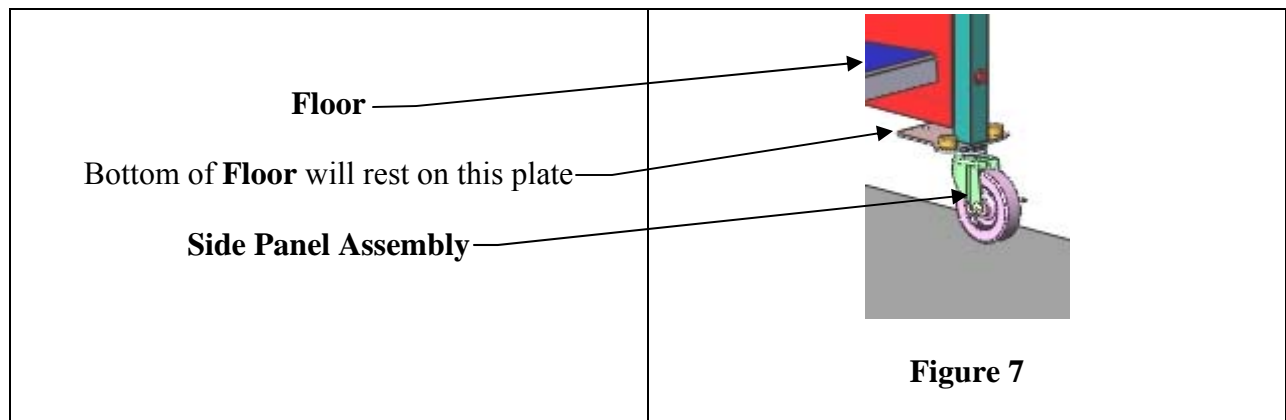

4. Lock brake on **Caster**.

5. Unlock brake on **Caster** on other side of **Floor**. Place front corner of **Floor** on **Plate, Base-Front Hinge**. (**Figure 7A**)

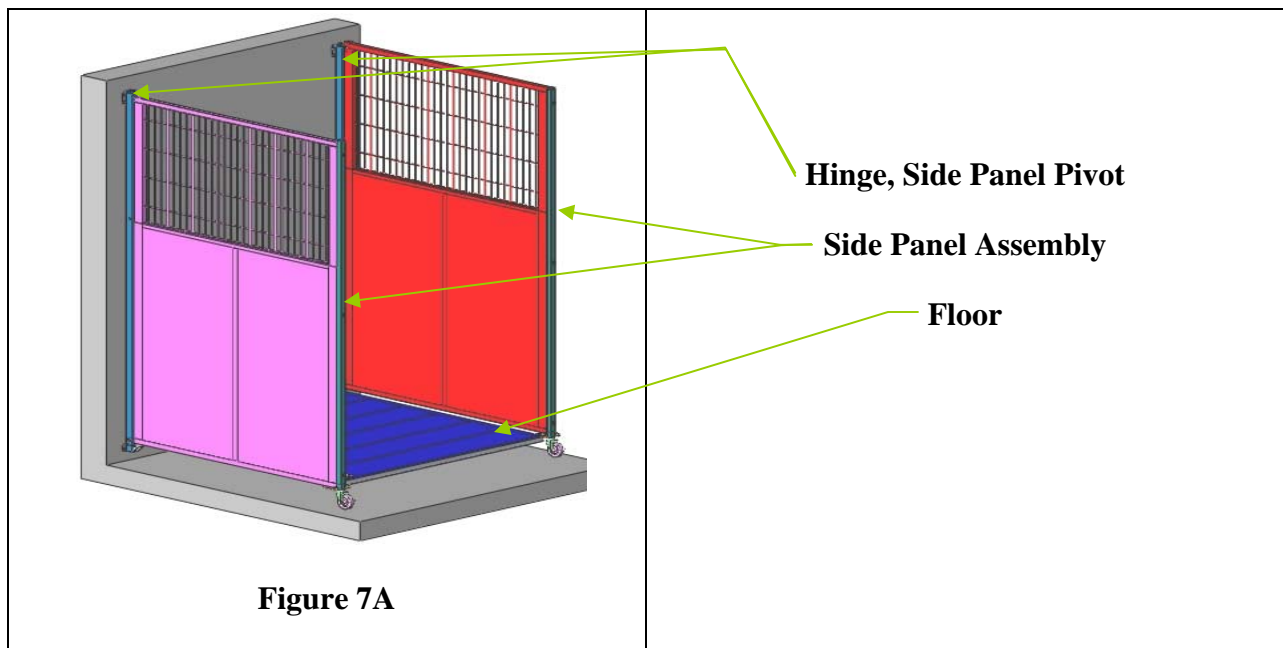

6. Lock brake on **Caster** of this **Side Panel Assembly**.

7. Take **Gate Panel** and place bottom on **T-K, Pin, Lower Hinge** located at front of **Side Panel Assemblies**. (2 places at bottom) (**Figure 7B**)

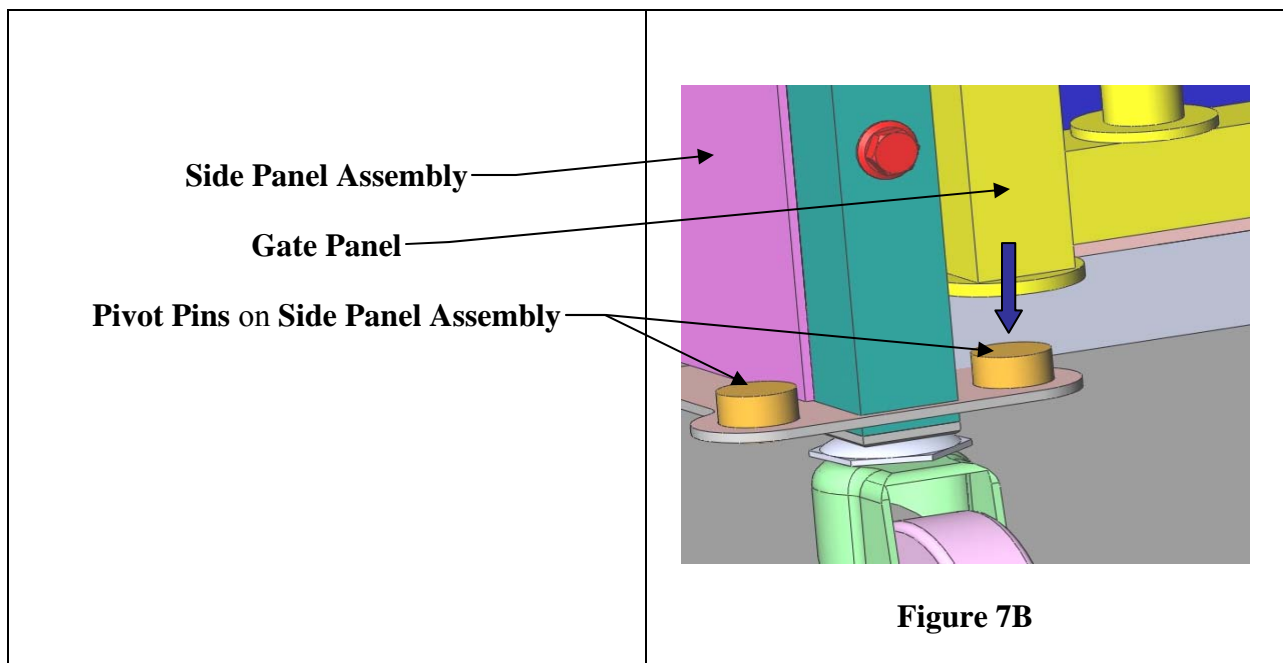

8. While one person is holding this up, a second person will mount the **Hinge, Upper Gate Pivot**. (Figure 7C)

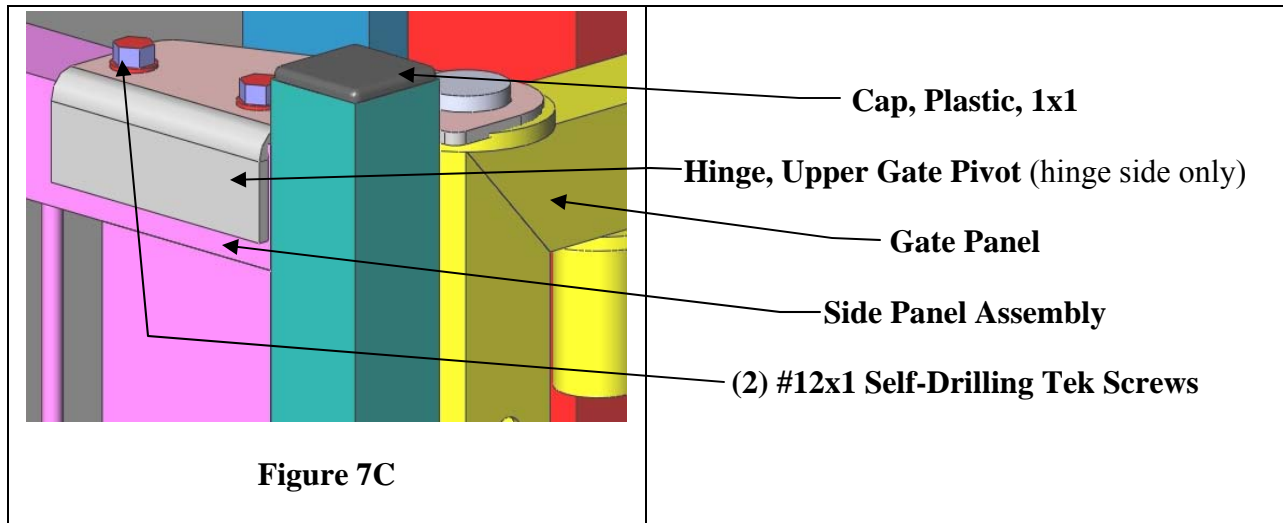

9. Next mount the **Latch, Sliding Bolt Door/Gate** to right front top of **Gate Panel** and top front of **Side Panel Assembly**. (Figure 7D)

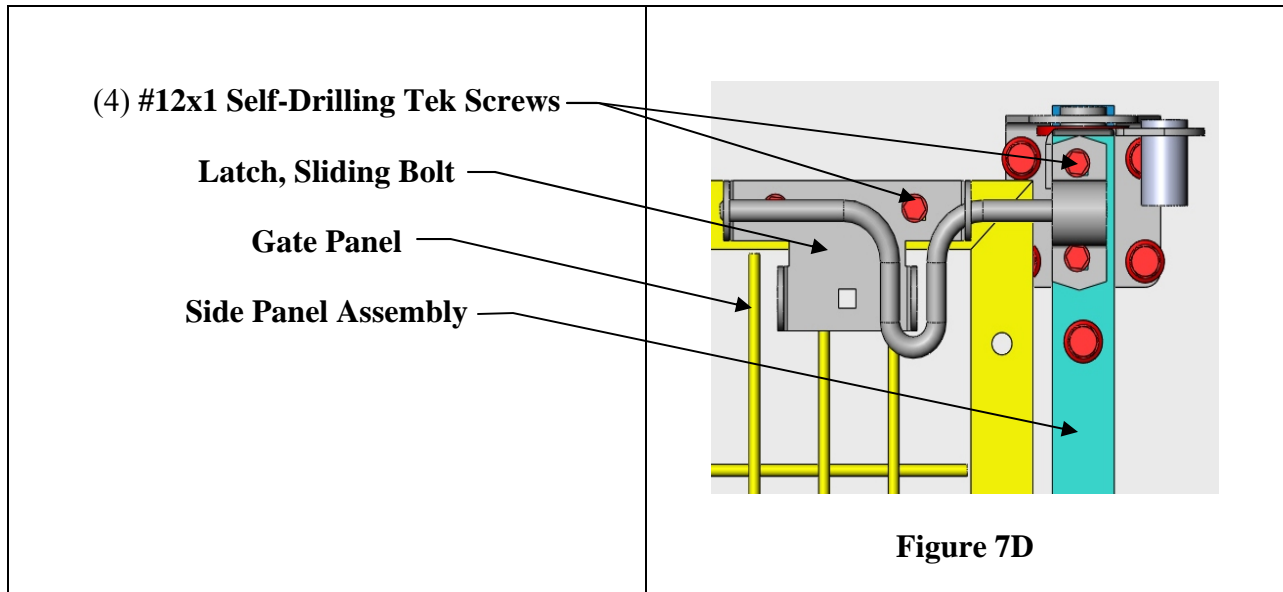

10. Continue to place these items on assembly you are building.

11. Reinstall **Doors**.

Note: After **Gate Panels** are installed they are not removable except by removing **Hinge, Upper Gate Pivot**.

I. Install Striker Bar and Latch Assembly

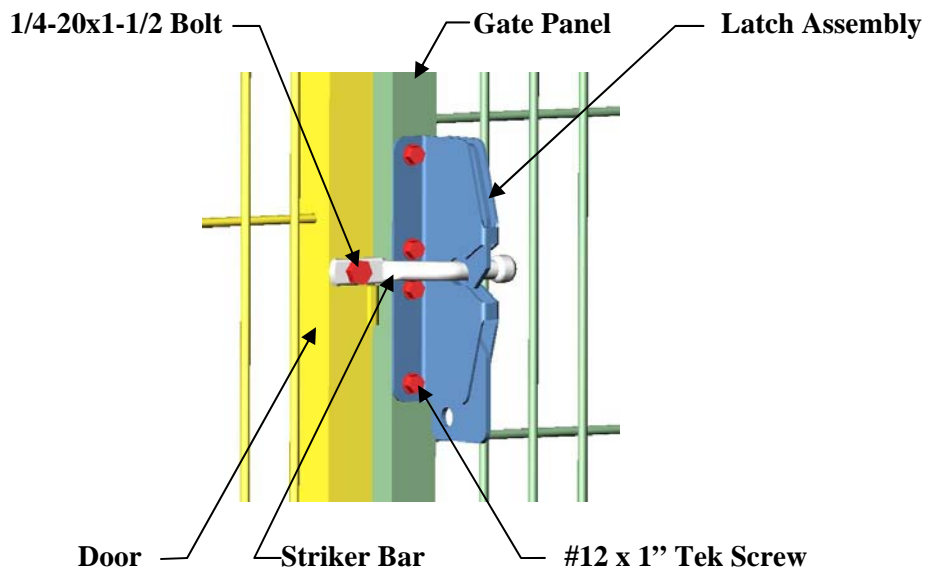

Figure 8

1. Install the **Striker Bar** to the pre-drilled **Door** using a **1/4"-20 x 1-1/2 Hex Bolt** and **1/4"-20 Nylock Nut** (**Figure 8**). Position the **Striker Bar** into a horizontal position.

Note:

To install the **Latch Assembly** to an **Optional Stainless Steel Gate Panel**, you must pre-drill the holes using a 3/16" cobalt drill bit through only one wall of tube for the **1" Tek Screws** by matching with the pre-drilled holes in the **Latch Assembly**.

2. Hold the **Latch Assembly** in place against the **Gate Panel** and close the **Door**. Make sure to center the **Striker Bar** within the latch pocket and latch looks straight. Using (4) **1" Tek Screws**, attach the **Latch Assembly** to the **Gate Panel** (**Figure 8**).

J. Folding Kennels

1. Raise **Floor** and lock in vertical position. (reference **Figures 3A** and **3B**)
2. Unlatch **Gate Panel** at top right side. Lift handle up and slide to the left. (reference **Figure 7D**)
3. Lift **Gate Panel** off lower pivot pins and rotate to back.
4. Unlock **Castors** and fold **Side Panel Assemblies** from the 1st one thru the next to last one toward the left side.
5. Fold last **Side Panel Assembly** on the right side to the right.
6. To unfold kennels reverse this order.